

CHAPTER 2

AO





# AO MEANING EARTH IN MAORI

Adventure! We all love it, we all seek it, but having the right tool for the job means that adventure can mean different things to different people. The AO is the Swiss Army knife of the Gravel genre. AO means “Earth” in Maori and New Zealand’s rugged landscape became the brief in developing one of the most versatile Gravel frames in the market.

Each year hundreds of adventurers embark on the Tour of Aotearoa, a 3,000km race from the tip of the North Island to the southernmost part of the South Island. Along the way, competitors will traverse some of the most spectacular and rough roads and terrains.







The AO has been specially designed to excel in all the variable conditions. With 42mm tire clearance with 700C wheels and the ability to accept 650B wheels at 47mm tire clearance, the AO can be fitted with 5 water bottles, dropper post, panniers, and mudguards making it an adventurer's perfect multi-tool.

Whether you are racing fast gravel events or long distance brevets the AO's ability to adjust its rear centre by up to 15mm will let you adjust its agility levels to suit your every need and desire, including running road tires for that one bike does it all quiver killer.

*Michael*

Designed in  
New Zealand









# FEATURES



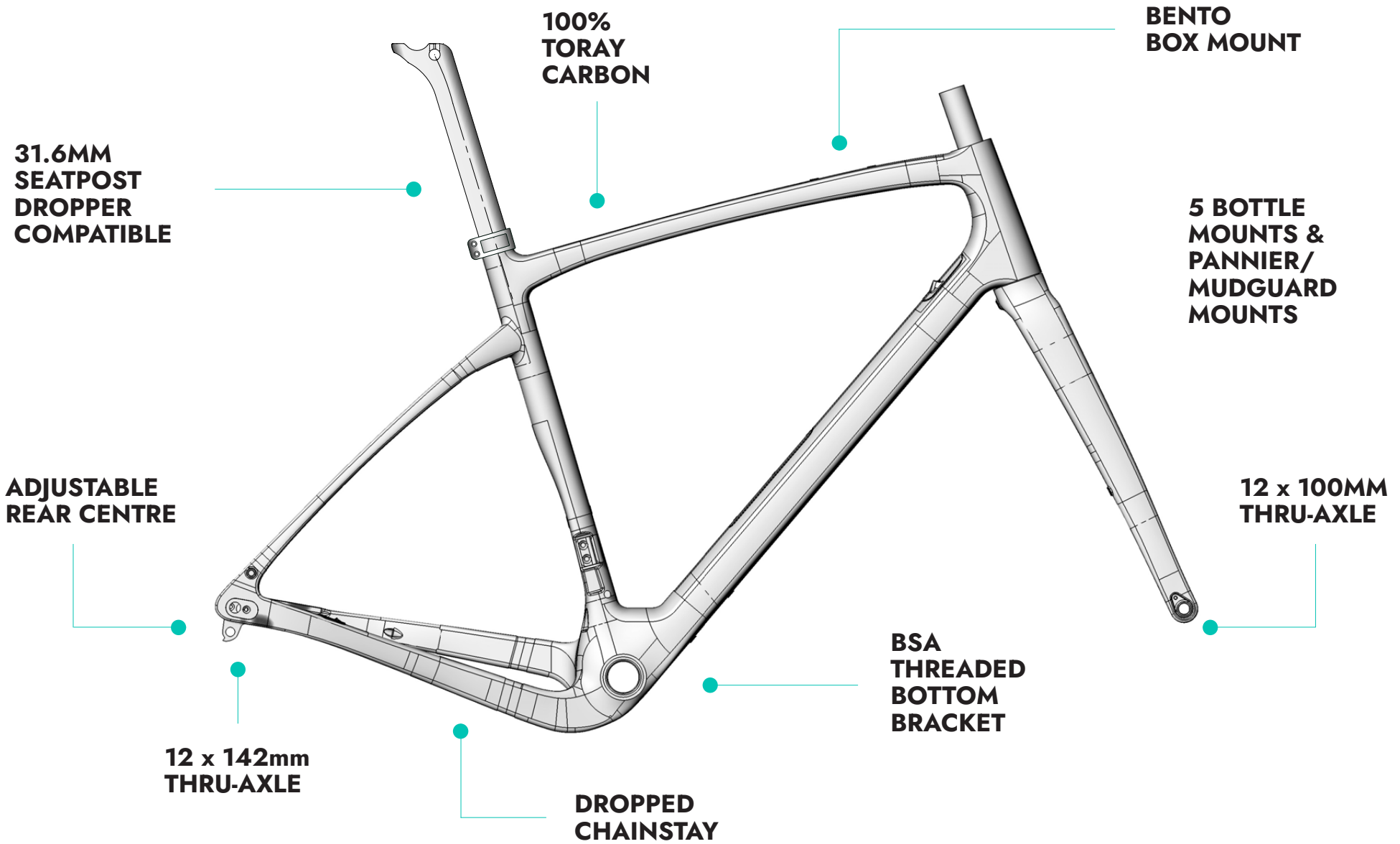







FLIP-CHIP

CNC REAR  
140/160MM  
BRAKE CALLIPER  
CARRIER

# ADJUSTABLE REAR-CENTRE

Via the Flip-Chips, the rear centre is adjustable by up to 15mm in 7.5mm increments. By adjusting the wheelbase you can dial in the ride quality that suits your terrain or sense of adventure.

1. 0mm Neutral Setting.
2. -7.5mm Reduces Rear Centre and increases agility.
3. +7.5mm Increases Rear Centre and creates a more subtle steering performance.

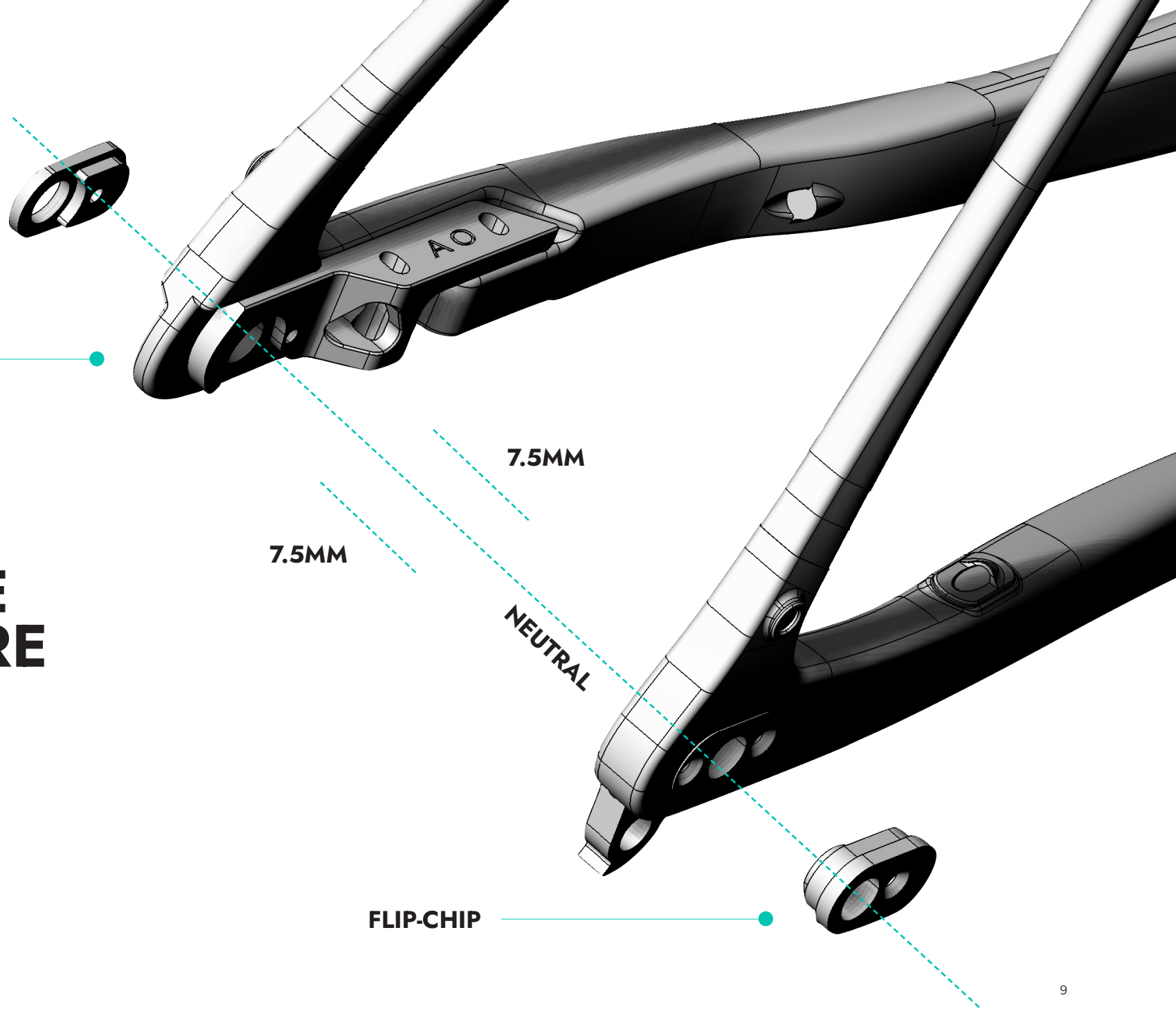

FLIP-CHIP



# INTEGRATED OPTIONS

There are never 2 Chapter2 bikes the same, and this is never more true than with how the AO can be configured. 2x, 1x, Dropper post or no dropper post, electronic or analogue gears you can configure the cable management with our supplied plates and internal routing systems to your exact requirements.



**1X CABLE  
GUIDE  
INCLUDED**

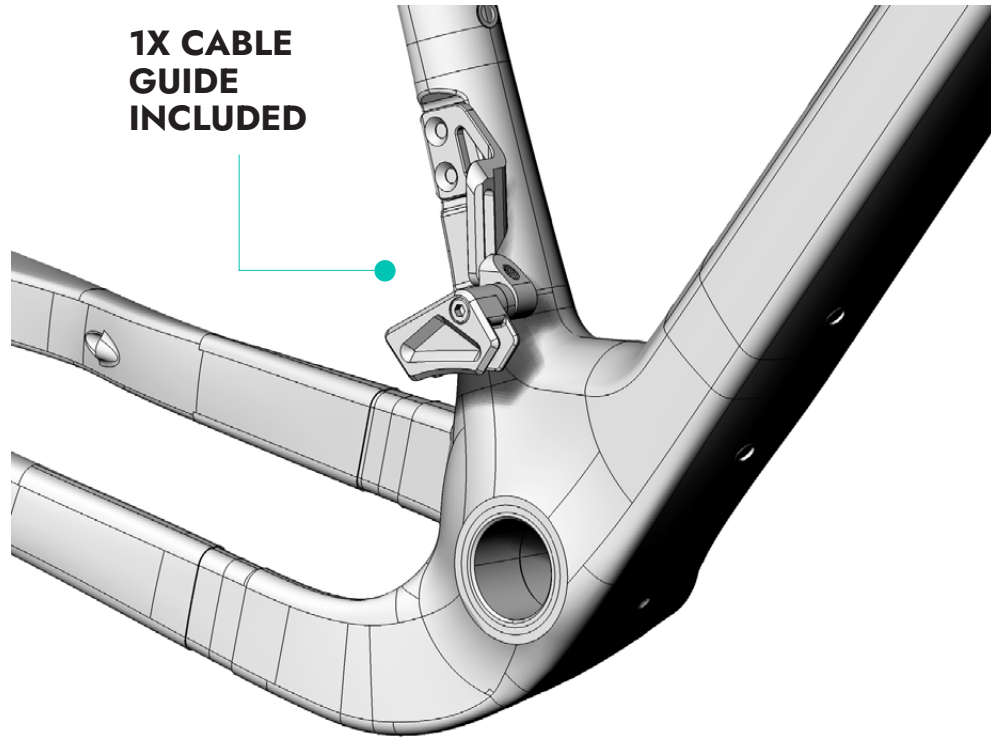

**REMOVABLE  
PANNIER/MUDGUARD  
MOUNT**

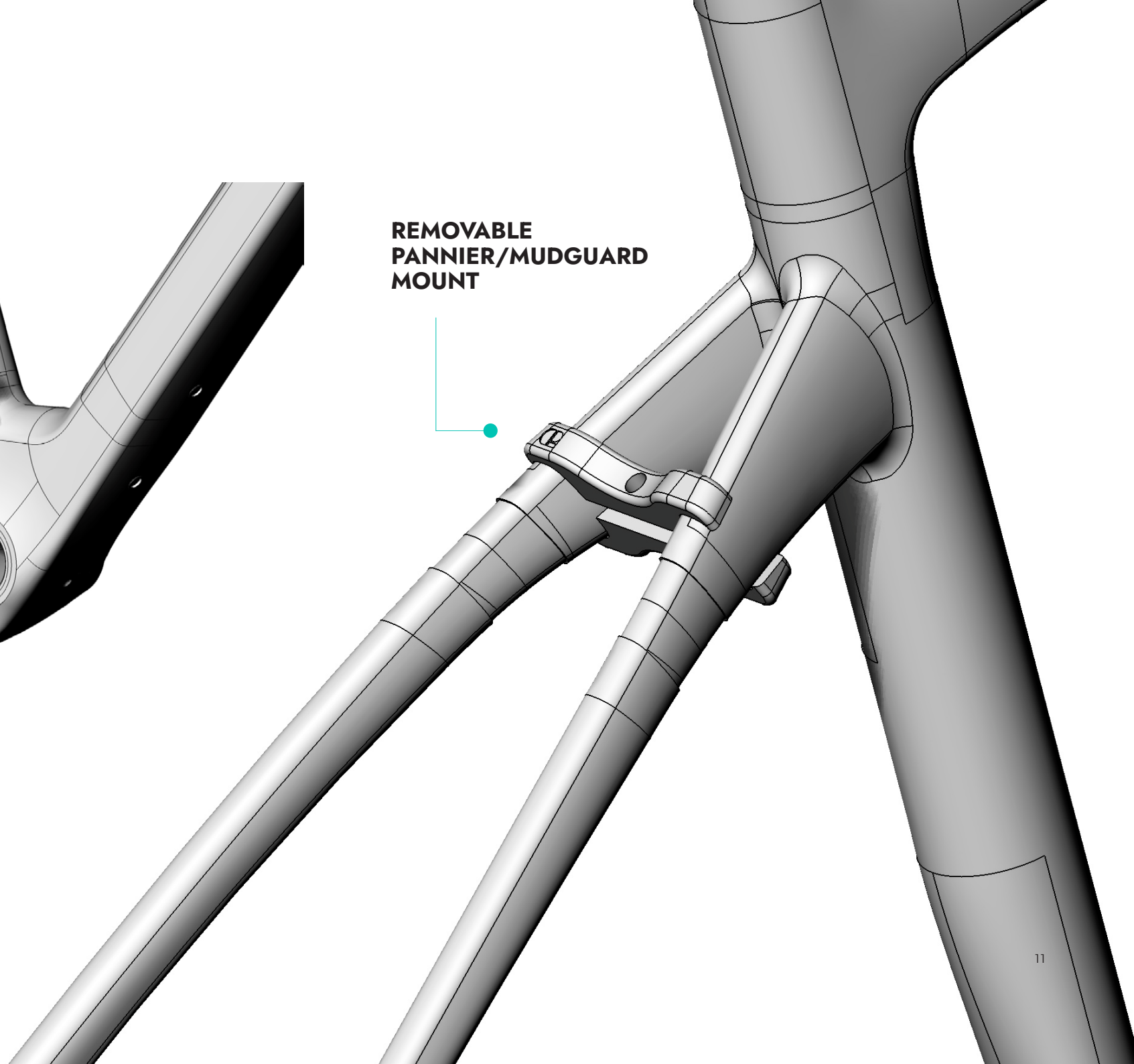



# MEDIA REVIEWS



**It offers plenty of performance through its light, stiff and comfortable carbon chassis, while clever features throughout add versatility.**

With the company's owner coming from a MTB background, it's not too surprising to see the AO taking on what I'd call a modern approach to gravel bike geometry.

C2 has done a really impressive job with the AO in how they've slightly tweaked some well-proven geometry numbers and produced a bike that truly does serve as one of the more well-rounded gravel bike offerings. A real quiver-killer, if you will.

**CyclingTips (Dave Rome)**

**C2 AO looks to add a couple more to that list. If I were to expand on the light, fast, responsive, line, I'd add in versatility and compatibility to that list.**

Obvious details are the dropped chainstay, ample clearance for a 2x drivetrain and tires, internal routing, rack or bag support mounts, what appears to be a few extra bosses for bags, as well as a third bottle mount.

The new C2 AO checks some pretty important boxes and delivers a package that is both friendly to road cyclists looking to get dirty, as well as dabble in some lightweight bikepacking.

**Radavist (John Watson)**





# GEOMETRY & SPECS





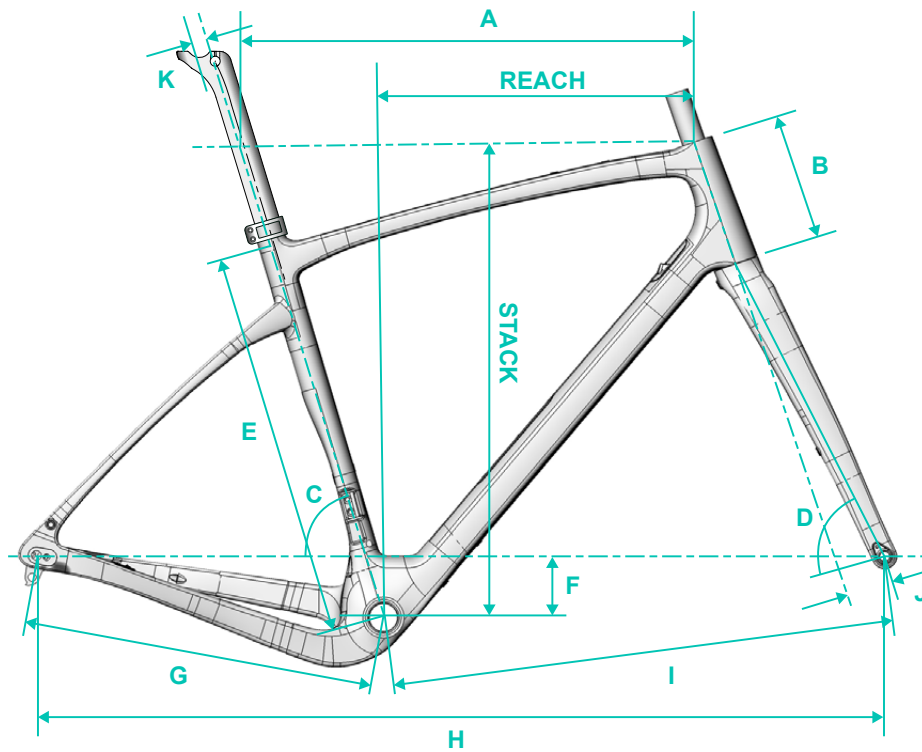

The AO features a higher stack than our all-road TERE, a longer wheelbase, lower BB and slacker head angle all which contribute to the super-stable but responsive ride when you veer off-road. We've blended the efficiency of a road bike with 'all-week' comfort which is a hallmark of genre defying gravel bikes.

	XS	S	M	L	XL
STACK	521	548	576	605	634
REACH	355	366	377	388	399
A	509	528	547	567	587
B	105	130	155	179	209
C	73.5°	73.5°	73.5°	73.5°	73.5°
D	69°	70°	71°	72°	72°
E	460	480	500	530	560
F	74	74	74	74	74
G	420 +/-7.5	420 +/-7.5	420 +/-7.5	420 +/-7.5	420 +/-7.5
H	998	1010	1021	1026	1046
I	589	601	612	617	638
J	55	55	55	50	50
K	15	15	15	15	15



## SPECIFICATIONS

Carbon	100% Made in Japan by Toray
Frame Sizes (5)	XS, S, M, L & XL
Fork Rakes (2)	XS, S, M (55 offset) and L, XL (50 offset)
Frame Weight	1180g Size M +/- 3%
Fork Weight	479g Uncut +/- 3%
Seatpost Weight	249g Size M +/- 3%
Handlebar/Stem (MANA)	C2 Alloy
Headset	C2 1-1/8" – 1.5"

## COMPATIBILITY

Mechanical & Electric Shifting	Versatile Groupset Options
Electronic Shifting	Shimano Di2, SRAM eTAP & Campagnolo EPS
Battery Type	Di2 SM-BTR-2 and EPS V3 Battery Compatible
Tire Clearance	(ISO 4mm) 42mm (700C) & 47mm (650B)
Brake Type	Disc Only
Bottom Bracket	BSA Threaded
Thru-Axle	FR 12x100mm, RR 12x142mm E-Thru M12x1.5mm

## ACCREDITATION

Safety Standard	EN ISO 4210:2014
-----------------	------------------

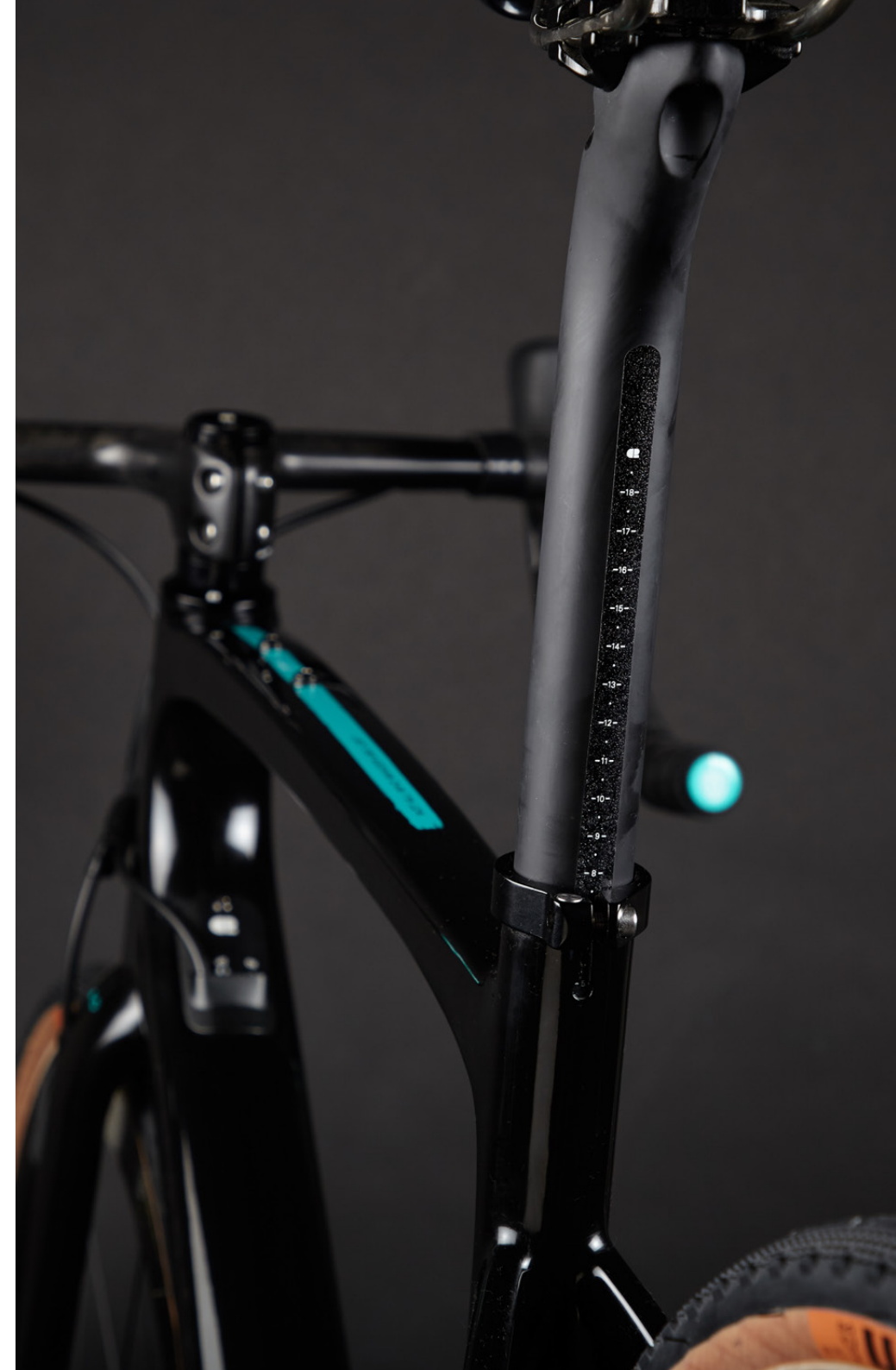





# WHAT YOU GET

- Frame
- Fork
- Stem
- C2 fork expansion bolt
- Headset
- Headset spacer kit
- Seatpost
- Thru Axles

## ADD ONS

- Mana Bar (Not included)



# COLOURWAYS





# TUHUA

GLOSS BLACK











NOT ALL WHO WANDER ARE LOST

AO

6Nm. Max.





AO



# HIRIWA

SILVER + UD











CHAPTER2

A0











# AOTEAROA

SKY + BLUE





















NEW ZEALAND.COM  
Licence No. 101081



# RANGIPO

EARTH TONES











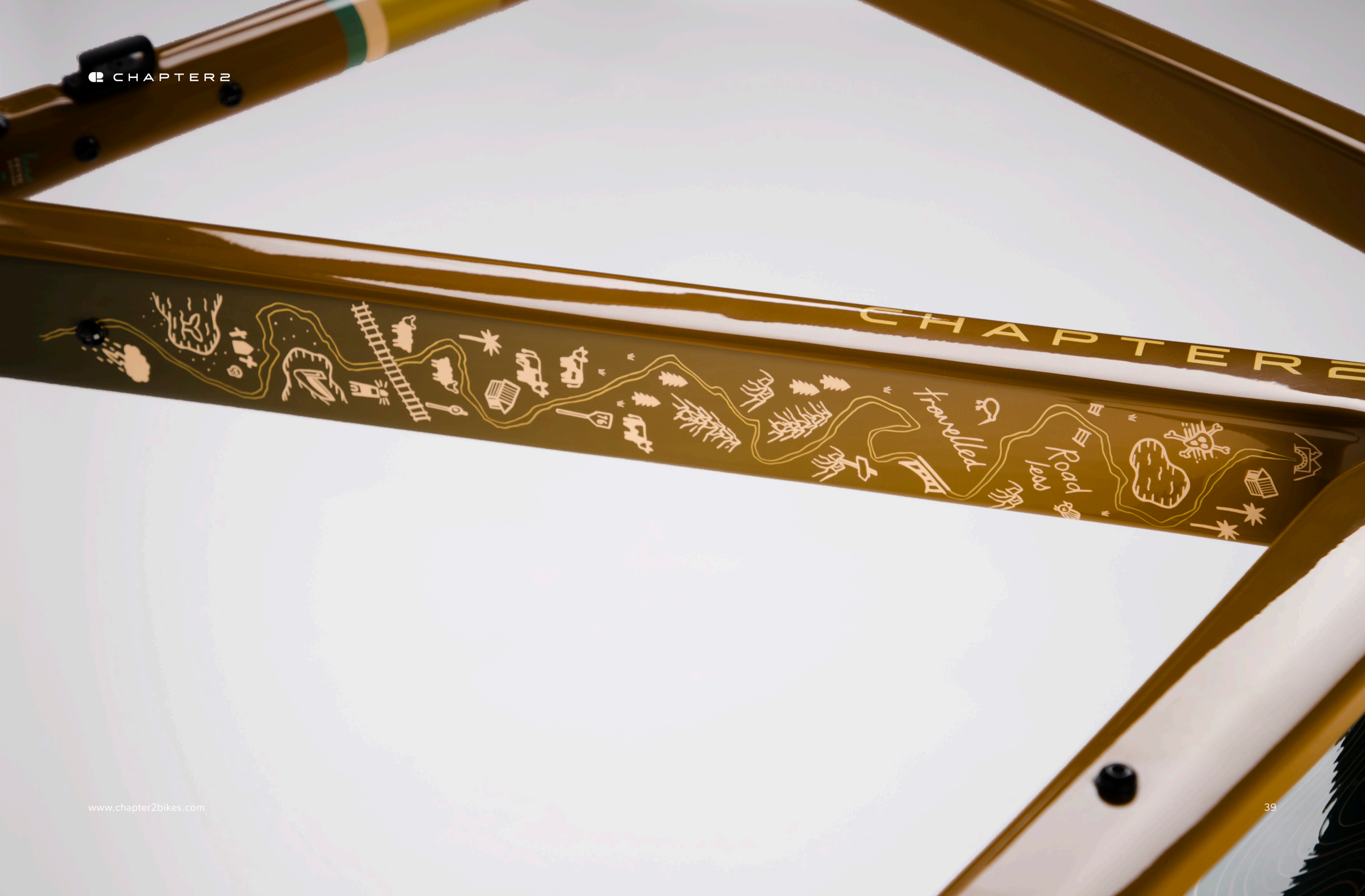

CHAPTER 2













AVAILABLE WORLDWIDE / CONTACT [INFO@CHAPTER2.CO.NZ](mailto:INFO@CHAPTER2.CO.NZ)



[WWW.CHAPTER2BIKES.COM](http://WWW.CHAPTER2BIKES.COM)